



megaspin 610

DIGITAL BALANCING MACHINE
WITH AUTOMATIC SPIN FOR
WHEELS UP TO 250 KG

PUSH
TO
START

LASER
LINE

LIFTING
SPINDLE



The new balancing machines for trucks have been developed paying particular attention to the safety of the operator and to the easiness of use, taking into account also ergonomics and technological innovation.

Digital panel

Digital panel with simple and intuitive interface. The software supports various correction programs useful to the operator, such as: Split, to hide the weights behind the spokes, OPT (unbalance optimization) and ALU for infinite correction positions with adhesive weights.

Large weight holder

The weight holder made with rotational moulding has been studied in detail to allow the operator to make the most of all the available space. The special compartments allow resting pliers, counterweights, cones, etc. in full safety.



megaspin 610

DIGITAL BALANCING MACHINE
WITH AUTOMATIC SPIN FOR
WHEELS UP TO 250 KG



“Push to start”

The unbalance measurement process starts only when the two buttons positioned on the side of the machine are simultaneously pressed; this eliminates the possibility of accidental damage for the operator, who can work safely even in the absence of wheel protection.

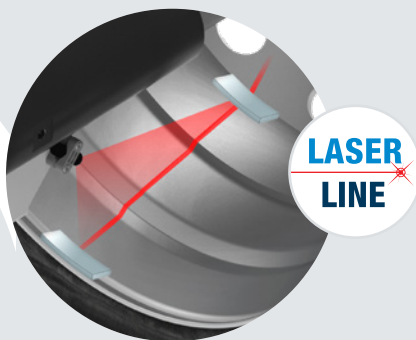

Laser line

The adhesive correction weights are positioned with great accuracy thanks to the laser line at “6 o’clock” position which identifies the application point of the weight.

LIFTING SPINDLE

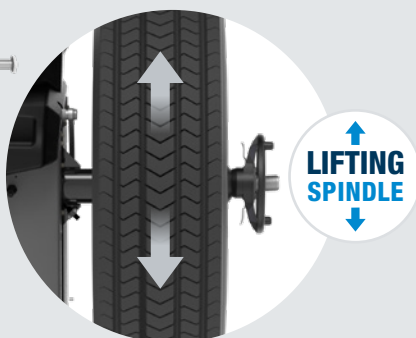

Built-in lift

The innovative spindle shaft that lifts and lowers acts as a lift built in the machine body, helping the operator during wheel loading and unloading. In fact, the wheel is loaded with no effort thanks to the lowest sliding trolley available on the market (59 mm) and is locked when it is still on the ground, ensuring a perfect centring in full safety conditions for the operator.

NOTE: sliding trolley available as an OPTION.

Standard accessories



Standard equipment composed of quick nut with spacer ring, pincer-hammer, 300 g. counterweight and WDC gauge

Optional accessories



IV/V CONES-GG-G40 KIT

To centre truck or bus wheels with a central hole of 202/221/281 mm Ø. Made up of IV and V cones, G40 disc and GG ring

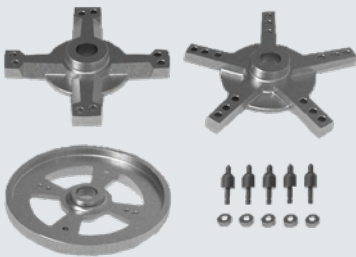

SR215

To centre wheels with 8 holes on 275/285.75 mm Ø and with 10 holes on 225/285.75/335 mm Ø. Supplied with centring adaptor, 5 and 4 armed spiders, stud bolts and screws

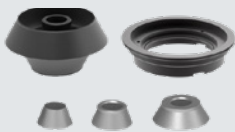

CAR ADAPTOR KIT

For wheels with a central hole of 45-194 mm Ø. Consists of 4 cones



SLIDING TROLLEY

Thanks to its height of only 59 mm, it allows for easy loading of the wheel.

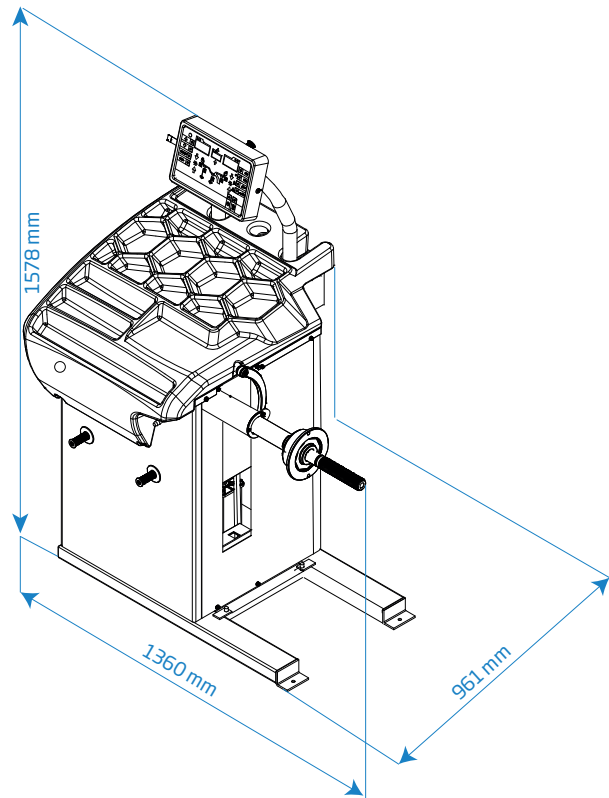

Technical Data

Single phase power supply	230V/1ph/50 hz 115V/1ph/60 Hz
Max. absorbed power	0,65 kW
Balancing speed	130 rpm (for car) / 80 rpm (for truck)
Measuring cycle for car/truck wheel	8 ÷ 20 s
Measurement uncertainty	± 0.5 g
Resolution	1 g (for car) / 10 g (for truck)
Average noise	< 70 dB (A)
Rim width setting range	1.5" ÷ 20" / 40 ÷ 510 mm
Rim diameter setting range	10" ÷ 30" / 265 ÷ 765 mm
Min./Max. compressed air pressure	8 ÷ 12 kg/cm ² / ~ 0.8 ÷ 1.2 MPa ~ 8 ÷ 12 bar / ~ 120 ÷ 165 psi
Max. wheel weight	250 kg
Max. wheel diameter	1380 mm
Machine weight	190 kg



HOFMANN MEGAPLAN GmbH
Hüttenstrasse 7 - 67550 Worms - Germany
T +49 06242 913 6666 - hm-mail@hofmann-megaplan.com
www.hofmann-megaplan.com